

Golden Hour Repair Tips

Detail B



Main stem is beveled flat on two sides for precise fit of minute hand. This ensures greater time keeping accuracy.

Detail A



Hour hand and counterbalance are together in one assembly. It's important that tear drop counterweight is aligned as shown above when replacing hour hand in crystal face.

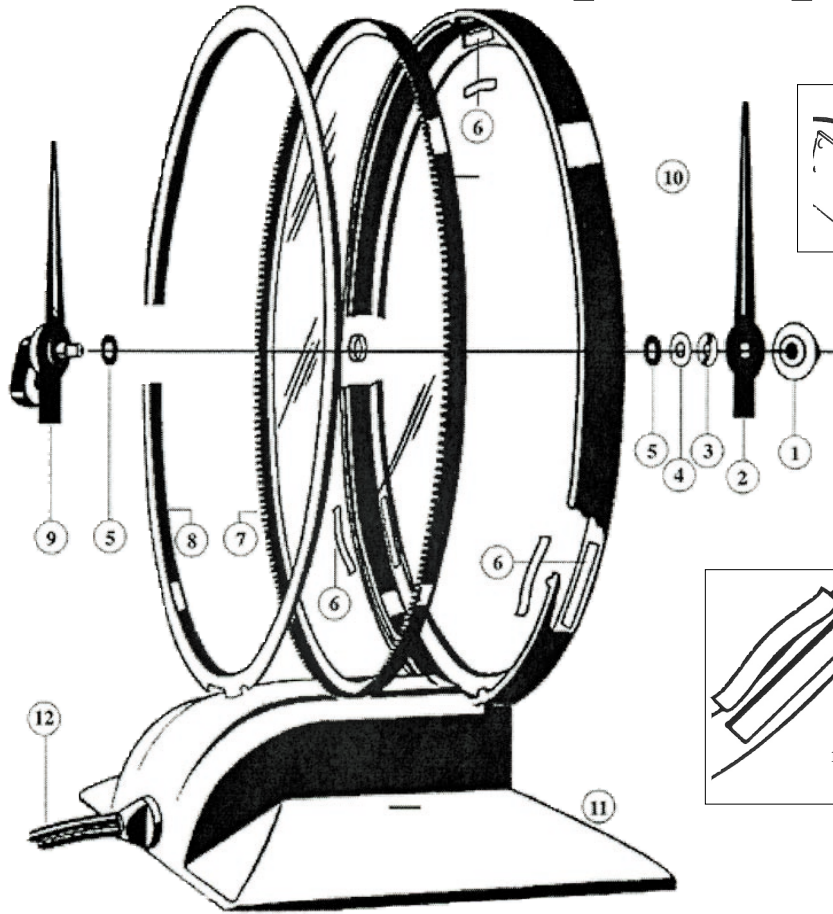

Detail D

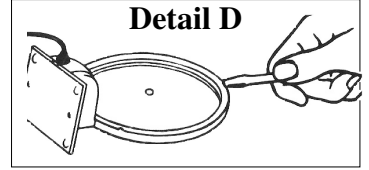

Detail C

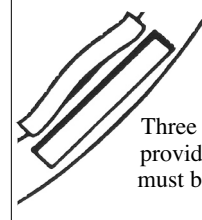

Three leaf springs fit into pockets provided in the gold ring. Springs must be in place to provide proper tension to crystal.

To Take Apart

1. Set both hands to the 12 o'clock position. Unscrew cone nut (1) at the front, minute hand (2), convex washer (3), flat washer (4), and one flat fiber washer (5), will come off in that order.
2. Hour hand assembly (9) removes from the back. Then remove one fiber washer (5).
3. Place clock on its face and remove gold retaining ring (8) from the back by prying gently with a screwdriver at the top. See "Detail D".
4. Remove entire crystal glass and gear ring (7). Remove the three small leaf springs (6) to prevent loss.

Parts List

- 1 Cone Nut
- 2 Minute Hand
- 3 Convex Tension Washer (1)
- 4 Flat Washer (1)
- 5 Fiber Washers (2)
- 6 Leaf Springs (3)
- 7 Glass And Gear Ring
- 8 Gold Retaining Ring
- 9 Hour Hand Assembly
- 10 Gold Dial Ring
- 11 Gold Base
- 12 Cord And Grommet

Golden Hour Repair Tip

If your Golden Hour clock runs fast or slow after replacing the motor, check to see if the glass is loose in the gear ring. The glass and gear ring were originally assembled with an adhesive and cured in an oven. Over the years the environment tends to break down this adhesive and the glass loosens from the metal gear ring. Installation of a new glass and gear ring assembly will eliminate this problem. Don't forget to reinstall the three leaf springs in the dial frame before installing the glass and gear ring.

To Put Together

1. Make sure all three leaf springs (6) are in their proper position. See Detail C above. Then slip in crystal glass and gear ring assembly (7) into place.
2. Put one fiber washer (5) on hour hand assembly (9) and place it through the hole in the glass and gear ring (7) at the 12 o'clock position.
3. Then place a fiber washer (5), flat washer (4), convex washer (3), and the minute hand (2), on the hand shaft. Line the minute hand (2) up with the hour hand assembly (9) at the 12 o'clock position and screw the cone nut (1) into place. Align the hour and minute hands before tightening the cone nut on the crystal.
4. Place the clock on a flat surface and adjust the hands to the 12 o'clock position. To set clock, move the minute hand clockwise to the correct minute and flip the hour hand to the correct hour.



The Golden Hour Clock Co.
7745 E. Redfield Road #500
Scottsdale, AZ 85260 U.S.A.
480-483-3711
clocks@timesavers.com
www.timesavers.com

Try Timesavers Premium 2-Day Blue Label Service

For orders call 1-800-552-1520 or 480-483-3711 • E-Mail: info@timesavers.com

Prices and descriptions are subject to change without notice.